

# DID YOU KNOW?

about our...



**NEW  
PRODUCT**

## Flat Round Sampson™ Washer

### FLAT ROUND SAMPSON™ WASHER HOT DIP GALVANISED / ASTM F436 / 26-45HRC

Part	Diameter	Outer Diameter	Inner Diameter	Thickness	
		OD (mm)	ID (mm)	Min	Max
WR43G050	1/2	27.8	14.3	2.5	4.5
WR43G062	5/8	34.2	18.3	3.1	4.5
WR43G075	3/4	38.1	21.5	3.1	4.5
WR43G087	7/8	45.3	24.6	3.5	4.5
WR43G100	1	52.4	28.6	3.5	4.5
WR43G112	1-1/8	58.8	31.8	3.5	4.5
WR43G125	1-1/4	65.1	36.5	3.5	4.5

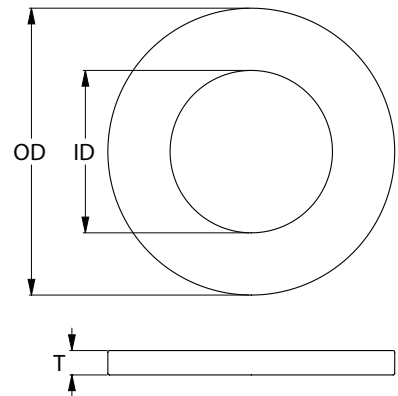
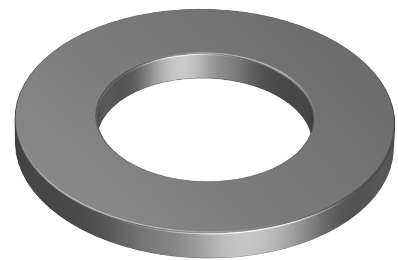

#### APPLICATIONS

- For use with high-tensile Grade 5 and above
- Suitable for HDG imperial stud-bolts

#### FEATURES

- Complies with ASTM F436
- 26-45 HRC



You can download this  
Test Certificate and/or  
Report from our website:

[hobson.com.au](http://hobson.com.au)

Disclaimer: while every reasonable effort has been made to ensure that this document is correct at the time of printing, Hobson Engineering®, its agencies and employees disclaim all liability in respect to anything or the consequences of anything done or omitted regarding the whole or any part of this document.

Bolt Tension | Anti-Vibration | Product Reliability | Traceability

[hobson.com.au](http://hobson.com.au) **QUALITY FASTENERS SINCE 1935**

