

# DID YOU KNOW?

about our...



**MORE  
SIZES +**

## Zinc Plated Rivet Nut Flat Round Knurl Open

### RIVET NUT FLAT ROUND KNURL OPEN ZINC PLATED (RoHS COMPLIANT) / HEC

Part	Size	Length L (mm)	Grip Range G (mm)		Hole Diameter D (mm)	Body Diameter B (mm)	Head Diameter A (mm)	Head Thickness T (mm)	Protrusion P (mm)
			Min	Max					
NRMSZFKOM04105	M4	10.5	0.5	2.0	6	5.9	9.0	1.0	5.4
NRMSZFKOM04120	M4	12.0	2.0	3.5	6	5.9	9.0	1.0	5.4
NRMSZFKOM05130	M5	13.0	0.5	2.5	7	6.9	10.0	1.0	8.0
NRMSZFKOM05165	M5	16.5	2.5	5.0	7	6.9	10.0	1.0	8.0
NRMSZFKOM06155	M6	16.5	0.5	3.0	9	8.9	13.0	1.3	10.0
NRMSZFKOM06195	M6	19.5	3.0	5.5	9	8.9	13.0	1.3	10.0
NRMSZFKOM08180	M8	18.0	0.5	3.0	11	10.9	14.5	1.5	11.0
NRMSZFKOM08210	M8	21.0	3.5	6.0	11	10.9	14.5	1.5	11.0
NRMSZFKOM10215	M10	21.5	1.0	4.0	13	12.9	17.0	1.7	15.0
NRMSZFKOM10240	M10	24.0	4.0	6.5	13	12.9	17.0	1.7	15.0
NRMSZFKOM12250	M12	25.0	1.0	4.0	16	15.9	22.0	2.0	15.0
NRMSZFKOM12280	M12	28.0	3.5	6.0	16	15.9	22.0	2.0	16.0



**NEW  
SIZES +**

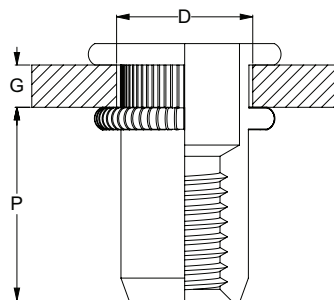
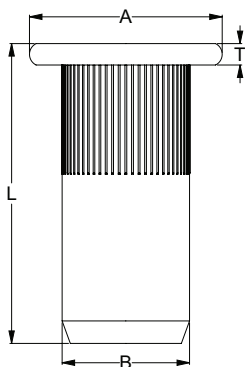

#### APPLICATIONS

- Used as a one-piece blind fastener
- Metal fabrication
- Automotive applications
- Used when the base material is too thin, cannot be tapped, or the back side is inaccessible to install a regular nut

#### FEATURES

- Knurled/splined to prevent rotation during installation and tightening
- Chamfered end to aid installation into the hole

Disclaimer: while every reasonable effort has been made to ensure that this document is correct at the time of printing, Hobson Engineering®, its agencies and employees disclaim all liability in respect to anything or the consequences of anything done or omitted regarding the whole or any part of this document. HEC product marking is the manufacturing mark of Hobson Engineering. HEC is a registered trademark of Hobson Engineering.

Bolt Tension | Anti-Vibration | Product Reliability | Traceability

[hobson.com.au](http://hobson.com.au) **QUALITY FASTENERS SINCE 1935**

