

DID YOU KNOW?

about our...



**NEW
PRODUCT**

Puma-X™ Panel Brace Anchor

PUMA-X™ PANEL BRACE ANCHOR
ZINC PLATED (RoHS COMPLIANT) / HEC / AS 3850.1

Part	QFind	Size	Length	Sleeve Length	Sleeve Diameter	Washer Diameter	Washer Thickness	Head Height	Wrench Size
			L (mm)	SL (mm)	W (mm)	D (mm)	T (mm)	H (mm)	AF (mm)
MAP88ZDM140115	MAP115	M14	115	43	20	38	3	13	30

APPLICATIONS

- Tilt panel bracing

FEATURES

- Tested by an independent NATA-accredited laboratory
- Large bolt head and heavy-duty washer
- Compression ring for improved fixture clamping
- Torque-controlled expansion anchor
- Removable anchor

Markings

For Puma-X™ anchor size M14

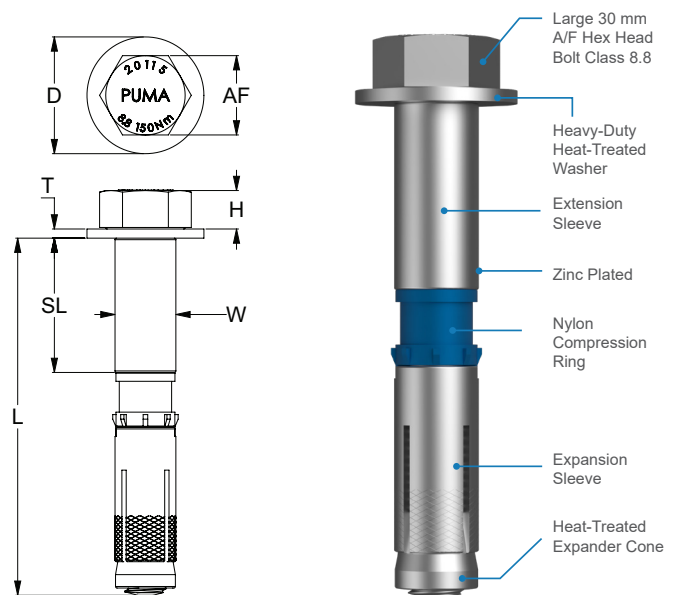
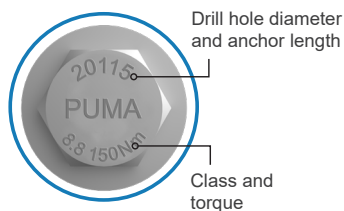

PUMA X™

Disclaimer: while every reasonable effort has been made to ensure that this document is correct at the time of printing, Hobson Engineering®, its agencies and employees disclaim all liability in respect to anything or the consequences of anything done or omitted regarding the whole or any part of this document. HEC product marking is the manufacturing mark of Hobson Engineering. HEC is a registered trademark of Hobson Engineering.

Bolt Tension | Anti-Vibration | Product Reliability | Traceability

hobson.com.au **QUALITY FASTENERS SINCE 1935**

