

DID YOU KNOW?

about our...



**NEW
PRODUCT**

Heavy-Duty Safety Anchor

HEAVY-DUTY SAFETY ANCHOR ZINC PLATED (ROHS COMPLIANT) / THREADED HEX BOLT HDS-B

Part	QFind	Size	Length L (mm)	Sleeve Length SL (mm)	Sleeve Diameter W (mm)	Washer Diameter D (mm)	Washer Thickness T (mm)	Head Height H (mm)	Wrench Size AF (mm)	Max. Fixture Thickness (mm)	Drill Hole (mm)
EAHMSZB18M100105	EAHB109	M10	105	54	15	25	2.5	6	17	15	15
EAHMSZB18M120120	EAHB114	M12	120	55	18	30	3.0	6	19	10	18
EAHMSZB18M120130	EAHB115	M12	130	65	18	30	3.0	6	19	20	18
EAHMSZB18M160150	EAHB119	M16	150	75	24	40	4.0	8	24	20	24
EAHMSZB18M200190	EAHB122	M20	190	107	28	50	4.0	11	30	30	28
EAHMSZB18M200220	EAHB123	M20	220	137	28	50	4.0	11	30	60	28

APPLICATIONS

- High-risk and safety-critical applications
- Structural applications
- Major infrastructure
- Bridges and tunnels

FEATURES

- ETA / AS 5216 approval — cracked and non-cracked concrete (Opt 1)
- Seismic C1 and C2 rating
- Fire rated
- High load performance
- Torque-controlled expansion anchor

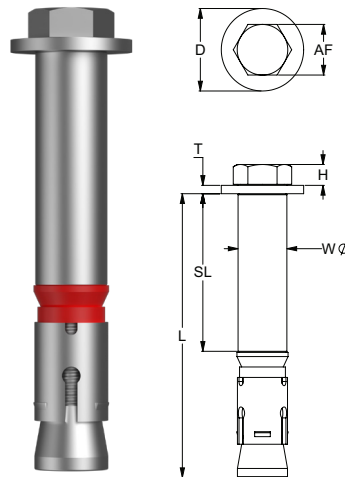

Opt 1



C1 & C2



Fire rated



Click on this icon and download ETA from Documents list at hobson.com.au

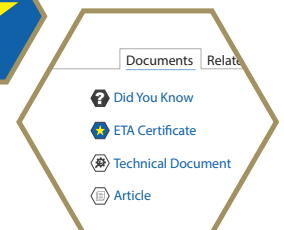

Disclaimer: while every reasonable effort has been made to ensure that this document is correct at the time of printing, Hobson Engineering®, its agencies and employees disclaim all liability in respect to anything or the consequences of anything done or omitted regarding the whole or any part of this document. HEC product marking is the manufacturing mark of Hobson Engineering. HEC is a registered trademark of Hobson Engineering.

Bolt Tension | Anti-Vibration | Product Reliability | Traceability

hobson.com.au **QUALITY FASTENERS SINCE 1935**

