



# HOBSON HDS-B, HDS-N, HDS-K HEAVY-DUTY ANCHOR

ETA 02/0030 (13/09/2019)

Option 1<sup>†</sup>

Seismic

Fire Resistant

DOC Link 10039

<sup>†</sup> Suitable for use in Cracked and Non-Cracked Concrete.

Qfind	Part Number on label	Size	Hole Size	Minimum Embedment	ETA Option	Fire Rating	Seismic C1	Seismic C2
EAHN106	EAHMSZN18M080090	M8x90	12mm	70mm	Option 1	✓	✓	✓
EAHN107	EAHMSZN18M080110	M8x110				✓	✓	✓
EAHN111	EAHMSZN18M100115	M10x115	15mm	85mm	Option 1	✓	✓	✓
EAHN115	EAHMSZN18M120115	M12x115	18mm	95mm	Option 1	✓	✓	✓
EAHN116	EAHMSZN18M120125	M12x125				✓	✓	✓
EAHN117	EAHMSZN18M120135	M12x135				✓	✓	✓
EAHN118	EAHMSZN18M120155	M12x155				✓	✓	✓
EAHN121	EAHMSZN18M160140	M16x140	24mm	120mm	Option 1	✓	✓	✓
EAHN122	EAHMSZN18M160160	M16x160				✓	✓	✓
EAHN123	EAHMSZN18M160190	M16x190				✓	✓	✓
EAHN125	EAHMSZN18M200180	M20x180	28mm	150mm	Option 1	✓	✓	✓
EAHN126	EAHMSZN18M200200	M20x200				✓	✓	✓
EAHK102	EAHMSZK18M120115	M12x115	18mm	95mm	Option 1	✓	✓	✓
EAHB105	EAHMSZB18M080085	M8x85	12mm	70mm	Option 1	✓	✓	✓
EAHB108	EAHMSZB18M100090	M10x90	15mm	60mm	Option 1	✓	✓	✓
EAHB109	EAHMSZB18M100105	M10x105				✓	✓	✓
EAHB110	EAHMSZB18M100120	M10x120				✓	✓	✓
EAHB113	EAHMSZB18M120110	M12x110	18mm	95mm	Option 1	✓	✓	✓
EAHB114	EAHMSZB18M120120	M12x120				✓	✓	✓
EAHB115	EAHMSZB18M120130	M12x130				✓	✓	✓
EAHB116	EAHMSZB18M120150	M12x150				✓	✓	✓
EAHB118	EAHMSZB18M160130	M16x130	24mm	120mm	Option 1	✓	✓	✓
EAHB119	EAHMSZB18M160150	M16x150				✓	✓	✓
EAHB120	EAHMSZB18M160180	M16x180				✓	✓	✓
EAHB122	EAHMSZB18M200190	M20x190	28mm	150mm	Option 1	✓	✓	✓
EAHB123	EAHMSZB18M200220	M20x220				✓	✓	✓



EAHMSZN18M~



EAHMSZK18M~

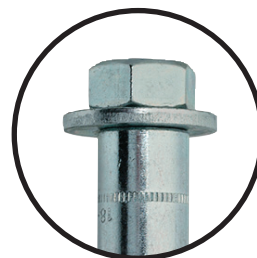

EAHMSZB18M~

Approval body for construction products  
and types of construction

Bautechnisches Prüfamt

An institution established by the Federal and  
Laender Governments



## European Technical Assessment

ETA-02/0030  
of 13 September 2019

English translation prepared by DIBt - Original version in German language

### General Part

Technical Assessment Body issuing the  
European Technical Assessment:

Deutsches Institut für Bautechnik

Trade name of the construction product

Highload Anchor SZ

Product family  
to which the construction product belongs

Mechanical anchor for use  
in concrete

Manufacturer

MKT  
Metall-Kunststoff-Technik GmbH & Co. KG  
Auf dem Immel 2  
67685 Weilerbach

Manufacturing plant

MKT  
Metall-Kunststoff-Technik GmbH & Co. KG  
Auf dem Immel 2  
67685 Weilerbach

This European Technical Assessment  
contains

22 pages including 3 annexes which form an integral part  
of this assessment

This European Technical Assessment is  
issued in accordance with Regulation (EU)  
No 305/2011, on the basis of

EAD 330232-00-0601

This version replaces

ETA-02/0030 issued on 10 July 2018

The European Technical Assessment is issued by the Technical Assessment Body in its official language. Translations of this European Technical Assessment in other languages shall fully correspond to the original issued document and shall be identified as such.

Communication of this European Technical Assessment, including transmission by electronic means, shall be in full. However, partial reproduction may only be made with the written consent of the issuing Technical Assessment Body. Any partial reproduction shall be identified as such.

This European Technical Assessment may be withdrawn by the issuing Technical Assessment Body, in particular pursuant to information by the Commission in accordance with Article 25(3) of Regulation (EU) No 305/2011.

## Specific Part

### 1 Technical description of the product

The Highload Anchor SZ is an anchor made of galvanised steel or made of stainless steel which is placed into a drilled hole and anchored by torque-controlled expansion. The following anchor types are covered:

- Anchor type SZ-B with threaded bolt,
- Anchor type SZ-S with hexagon head screw,
- Anchor type SZ-SK with countersunk washer and countersunk screw.

The product description is given in Annex A.

### 2 Specification of the intended use in accordance with the applicable European Assessment Document

The performances given in Section 3 are only valid if the anchor is used in compliance with the specifications and conditions given in Annex B.

The verifications and assessment methods on which this European Technical Assessment is based lead to the assumption of a working life of the anchor of at least 50 years. The indications given on the working life cannot be interpreted as a guarantee given by the producer, but are to be regarded only as a means for choosing the right products in relation to the expected economically reasonable working life of the works.

### 3 Performance of the product and references to the methods used for its assessment

#### 3.1 Mechanical resistance and stability (BWR 1)

Essential characteristic	Performance
Characteristic resistance to tension load (static and quasi-static loading)	See Annex C1 to C4
Characteristic resistance to shear load (static and quasi-static loading)	See Annex C5 to C6
Characteristic resistance and displacements for seismic performance category C1 and C2	See Annex C7 to C8
Displacements	See Annex C10 to C11
Durability	See Annex B1

#### 3.2 Safety in case of fire (BWR 2)

Essential characteristic	Performance
Reaction to fire	Class A1
Resistance to fire	See Annex C9

### 4 Assessment and verification of constancy of performance (AVCP) system applied, with reference to its legal base

In accordance with the European Assessment Document EAD 330232-00-0601 the applicable European legal act is: [96/582/EC].

The system to be applied is: 1

**5 Technical details necessary for the implementation of the AVCP system, as provided for in the applicable EAD**

Technical details necessary for the implementation of the AVCP system are laid down in the control plan deposited with Deutsches Institut für Bautechnik.

Issued in Berlin on 13 September 2019 by Deutsches Institut für Bautechnik

BD Dipl.-Ing. Andreas Kummerow  
Head of Department

*beglaubigt:*  
Lange

## Highload Anchor SZ

### Fastener type SZ-B with threaded bolt

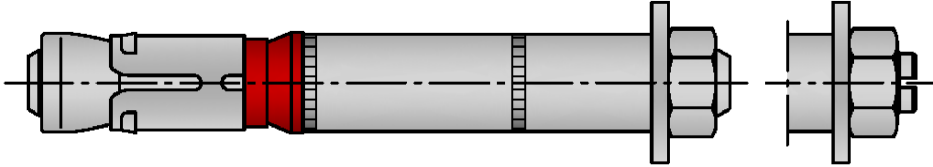

SZ-B (M6-M24)  
SZ-B (M8-M16) A4

### Fastener type SZ-S with hexagon head screw

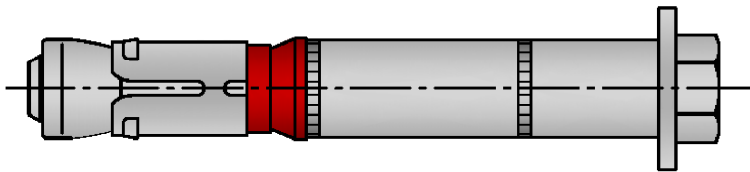

SZ-S (M6-M24)  
SZ-S (M8-M16) A4

### Fastener type SZ-SK with countersunk washer and countersunk screw

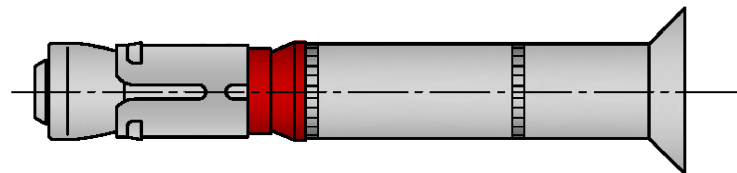

SZ-SK (M6-M12)  
SZ-SK (M8-M12) A4

## Installation situation

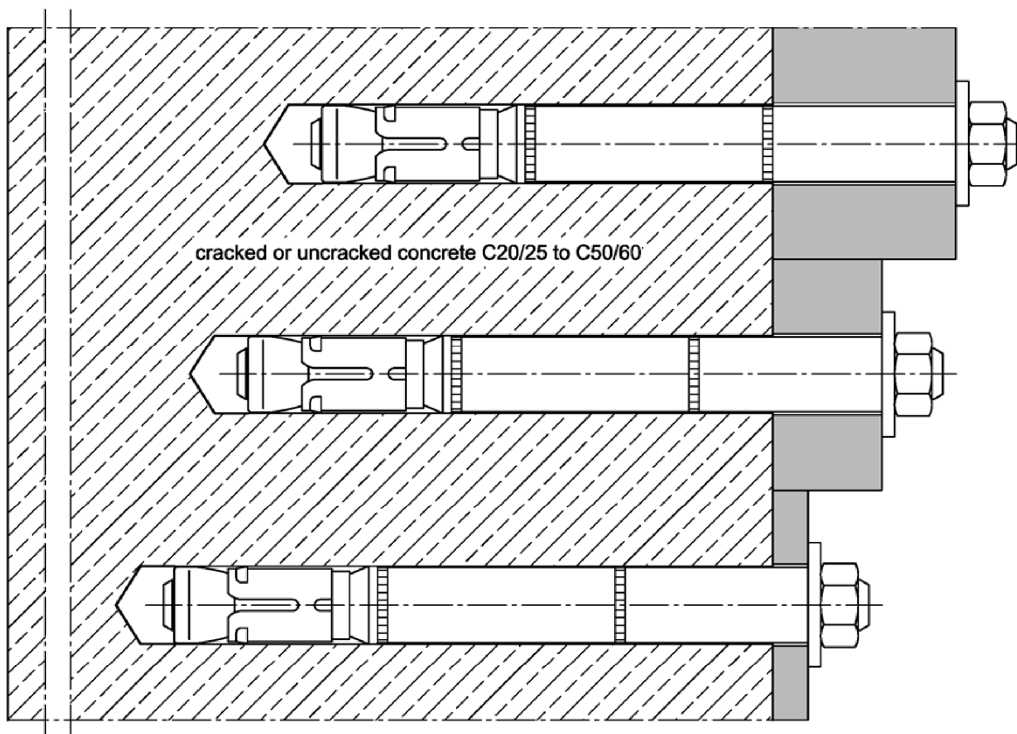

## Highload Anchor SZ

Product description  
Product and installation situation

Annex A1

**SZ-B**

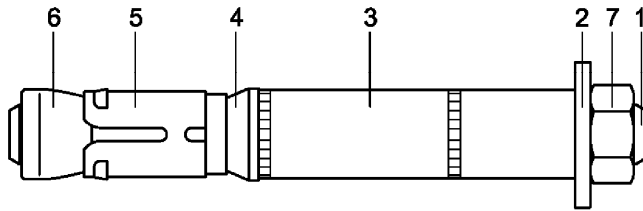

**SZ-S**

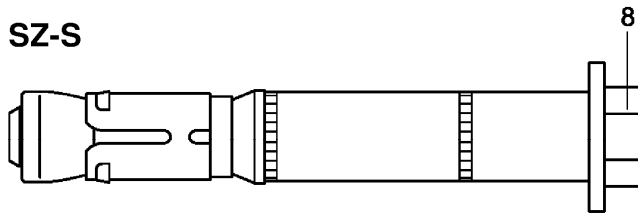

**SZ-SK**

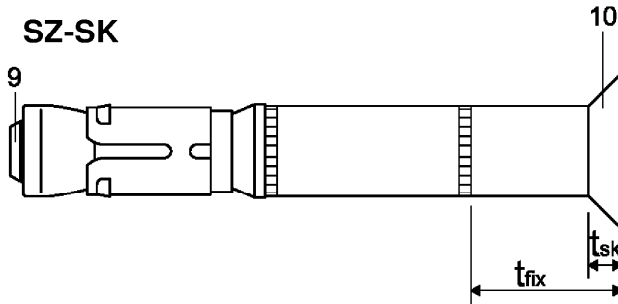

**Marking:**

- expansion sleeve:
- Identifying mark of manufacturing plant ◇
  - additional marking of stainless steel A4 A4
  - Anchor identity (alternatively on distance sleeve) SZ
  - size of thread (alternatively M10 on distance sleeve)

- Distance sleeve:
- Diameter 15
  - max. thickness of fixture  $t_{fix,max}$  for  $h_{ef,min}$  25
  - additional marking for countersunk version SK

marking on the washer of anchor size SZ 24/M16L L

**Table A1: Designation of fastener parts and materials**

Part	Designation	Materials galvanized $\geq 5 \mu\text{m}$ , acc. to EN ISO 4042:1999	Stainless steel A4
1	Threaded bolt	Steel, Strength class 8.8, EN ISO 898-1:2013	Stainless steel, 1.4401, 1.4404 or 1.4571, EN 10088:2014
2	Washer	Steel, EN 10139:2016	Stainless steel, EN 10088:2014
3	Distance sleeve	Steel tube EN 10305-2:2016, EN 10305-3:2016;	Steel tube stainless steel, 1.4401, 1.4404 or 1.4571; EN 10217-7:2014, EN 10216-5:2013
4	Ring	Polyethylene	Polyethylene
5	Expansion sleeve	Steel, EN 10139:2016	Stainless steel, 1.4401, 1.4404 or 1.4571, EN 10088:2014
6	Threaded cone	Steel EN 10083-2:2006	Stainless steel, 1.4401, 1.4404 or 1.4571, EN 10088:2014
7	Hexagon nut	Steel, Strength class 8, EN ISO 898-2:2012	Stainless steel, strength class 70, EN ISO 3506-2:2009
8	Hexagon head screw	Steel, Strength class 8.8, EN ISO 898-1:2013	Stainless steel, strength class 70, EN ISO 3506-1:2009
9	Countersunk screw	Steel, Strength class 8.8, EN ISO 898-1:2013	Stainless steel, strength class 70, EN ISO 3506-1:2009
10	Countersunk washer	Steel, EN 10083-2:2006	Stainless steel, 1.4401, 1.4404 or 1.4571, EN 10088:2014, zinc plated

**Highload Anchor SZ**

**Product description**  
Marking and materials

**Annex A2**

## Specification of intended use

Highload Anchor SZ, steel zinc plated	10/M6	12/M8	15/M10	18/M12	24/M16	24/ M16L	28/M20	32/M24
Static or quasi-static action	✓							
Seismic action (SZ-B and SZ-S)	-	C1 + C2						
Seismic action (SZ-SK)	-	C1 + C2				-		
Fire exposure	R 30 ... R 120							
Highload Anchor SZ, stainless steel A4	12/M8	15/M10	18/M12	24/M16				
Static or quasi-static action	✓							
Seismic action (SZ-B and SZ-S)	C1 + C2							
Seismic action (SZ-SK)	C1 + C2			-				
Fire exposure	R30 ... R120							

### Base materials:

- Cracked and uncracked concrete
- Compacted, reinforced or unreinforced normal weight concrete (without fibers) according to EN 206:2013 + A1:2016
- Strength classes C20/25 to C50/60 according to EN 206:2013 + A1:2016

### Use conditions (Environmental conditions):

- Structures subject to dry internal conditions (zinc plated steel or stainless steel).
- Structures subject to external atmospheric exposure (including industrial and marine environment) and to permanently damp internal conditions, if no particular aggressive conditions exist (stainless steel).

Note: Particular aggressive conditions are e.g. permanent, alternating immersion in seawater or the splash zone of seawater, chloride atmosphere of indoor pools or atmosphere with extreme chemical pollution (e.g. in desulphurization plants or road tunnels where de-icing materials are used.)

### Design:

- Anchorages are designed under the responsibility of an engineer experienced in anchorages and concrete work.
- Verifiable calculation notes and drawings are prepared taking account of the loads to be anchored. The position of the fastener is indicated on the design drawings (e.g. position of the fastener relative to reinforcement or to supports, etc.).
- Design according to EN 1992-4:2018 and Technical Report TR055

### Installation:

- Fastener installation carried out by appropriately qualified personnel and under the obligation of the person responsible for technical matters on site.
- Compliance with the effective anchorage depth. For fastenings with anchorage depths  $h_{ef} > h_{ef,min}$  the usable thickness of fixture is reduced by  $h_{ef} - h_{ef,min}$ .
- Use as supplied by the manufacturer without replacing individual parts.
- Drilling of hole only by hammer drilling (use of vacuum drill bits is admissible)

## Highload Anchor SZ

Intended use  
Specification of intended use

Annex B1

### Installation situation

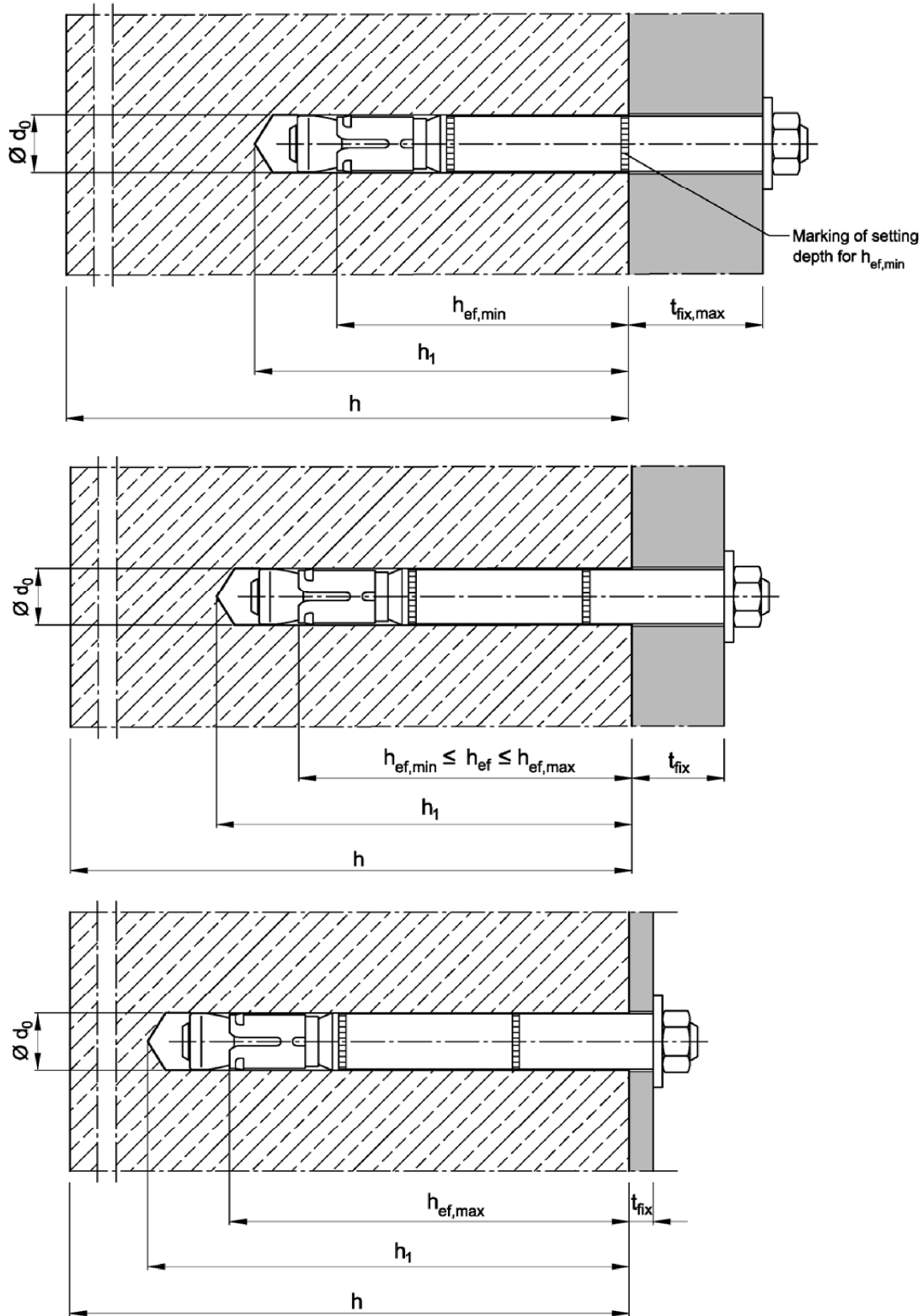

**Highload Anchor SZ**

**Intended use**  
Installation situation

**Annex B2**

**Table B1: Installation parameters, steel zinc plated**

Fastener size			10/M6	12/M8	15/M10	18/M12	24/M16	24/ M16L	28/M20	32/M24
Size of thread		[-]	M6	M8	M10	M12	M16	M16	M20	M24
Minimum effective anchorage depth	$h_{ef,min}$	[mm]	50	60	71	80	100	115	125	150
Maximum effective anchorage depth	$h_{ef,max}$	[mm]	76	100	110	130	114	150	185	210
Nominal diameter of drill bit	$d_0 =$	[mm]	10	12	15	18	24	24	28	32
Cutting diameter of drill bit	$d_{cut} \leq$	[mm]	10,45	12,5	15,5	18,5	24,55	24,55	28,55	32,7
Depth of drill hole	$h_1 \geq$	[mm]	$h_{ef} + 15$	$h_{ef} + 20$	$h_{ef} + 24$	$h_{ef} + 25$	$h_{ef} + 30$	$h_{ef} + 30$	$h_{ef} + 35$	$h_{ef} + 30$
Diameter of clearance hole in the fixture	$d_f \leq$	[mm]	12	14	17	20	26	26	31	35
Thickness of countersunk washer SZ-SK	$t_{sk}$	[mm]	4	5	6	7	-	-	-	-
Minimum thickness of fixture SZ-SK	$t_{fix min}^{2)}$	[mm]	8	10	14	18	-	-	-	-
Installation torque	$T_{inst}$ (SZ-B, SZ-S)	[Nm]	15	30	50	80	160	160	280	280
	$T_{inst}$ (SZ-SK)	[Nm]	10	25	55	70	-	-	-	-
Minimum thickness of member	$h_{min}$	[mm]	$h_{ef} + 50$	$h_{ef} + 60$	$h_{ef} + 69$	$h_{ef} + 80$	$h_{ef} + 100$	$h_{ef} + 115$	$h_{ef} + 125$	$h_{ef} + 150$
Minimum spacing <sup>1) 3)</sup> cracked concrete	$s_{min}$	[mm]	50	50	60	70	100	100	125	150
	for $c \geq$	[mm]	50	80	120	140	180	180	300	300
Minimum edge distance <sup>1) 3)</sup> cracked concrete	$c_{min}$	[mm]	50	55	60	70	100	100	200	150
	for $s \geq$	[mm]	50	100	120	160	220	220	350	300
Minimum spacing <sup>1) 3)</sup> uncracked concrete	$s_{min}$	[mm]	50	60	60	70	100	100	125	150
	for $c \geq$	[mm]	80	100	120	140	180	180	300	300
Minimum edge distance <sup>1) 3)</sup> uncracked concrete	$c_{min}$	[mm]	50	60	60	70	100	100	200	150
	for $s \geq$	[mm]	100	120	120	160	220	220	350	300

<sup>1)</sup> Intermediate values by linear interpolation

<sup>2)</sup> Depending on the existing shear load, the thickness of the fixture may be reduced to the thickness of the countersunk washer  $t_{sk}$  (see Annex A2). It must be verified that the present shear load can be transferred completely into the distance sleeve (bearing of hole).

<sup>3)</sup> For fire exposure from more than one side  $c \geq 300$  mm or  $c_{min} \geq 300$  mm applies.

**Highload Anchor SZ**

**Intended use**  
Installation parameters, steel zinc plated

**Annex B3**

**Table B2: Installation parameters, stainless steel A4**

Fastener size			12/M8	15/M10	18/M12	24/M16
Size of thread		[-]	M8	M10	M12	M16
Minimum effective anchorage depth	$h_{ef,min}$	[mm]	60	71	80	100
Maximum effective anchorage depth	$h_{ef,max}$	[mm]	100	110	130	150
Nominal diameter of drill bit	$d_0 =$	[mm]	12	15	18	24
Cutting diameter of drill bit	$d_{cut} \leq$	[mm]	12,5	15,5	18,5	24,55
Depth of drill hole	$h_1 \geq$	[mm]	$h_{ef} + 20$	$h_{ef} + 24$	$h_{ef} + 25$	$h_{ef} + 30$
Diameter of clearance hole in the fixture	$d_f \leq$	[mm]	14	17	20	26
Thickness of countersunk washer SZ-SK	$t_{sk}$	[mm]	5	6	7	-
Minimum thickness of fixture SZ-SK	$t_{fix,min}^{2)}$	[mm]	10	14	18	-
Installation torque	$T_{inst} (SZ-B)$	[Nm]	35	55	90	170
	$T_{inst} (SZ-S)$	[Nm]	30	50	80	170
	$T_{inst} (SZ-SK)$	[Nm]	17,5	42,5	50	-
Minimum thickness of member	$h_{min}$	[mm]	$h_{ef} + 60$	$h_{ef} + 69$	$h_{ef} + 80$	$h_{ef} + 100$
Minimum spacing <sup>1) 3)</sup> cracked concrete	$s_{min}$	[mm]	50	60	70	80
	for $c \geq$	[mm]	80	120	140	180
Minimum edge distance <sup>1) 3)</sup> cracked concrete	$c_{min}$	[mm]	50	60	70	80
	for $s \geq$	[mm]	80	120	160	200
Minimum spacing <sup>1) 3)</sup> uncracked concrete	$s_{min}$	[mm]	50	60	70	80
	for $c \geq$	[mm]	80	120	140	180
Minimum edge distance <sup>1) 3)</sup> uncracked concrete	$c_{min}$	[mm]	50	85	70	180
	for $s \geq$	[mm]	80	185	160	80

<sup>1)</sup> Intermediate values by linear interpolation

<sup>2)</sup> Depending on the existing shear load, the thickness of the fixture may be reduced to the thickness of the countersunk washer  $t_{sk}$  (see Annex A2). It must be verified that the present shear load can be transferred completely into the distance sleeve (bearing of hole).

<sup>3)</sup> For fire exposure from more than one side  $c \geq 300$  mm or  $c_{min} \geq 300$  mm applies.

**Highload Anchor SZ**

**Intended use**  
Installation parameters, stainless steel A4

**Annex B4**

### Installation instructions

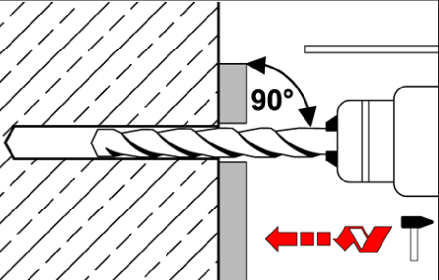
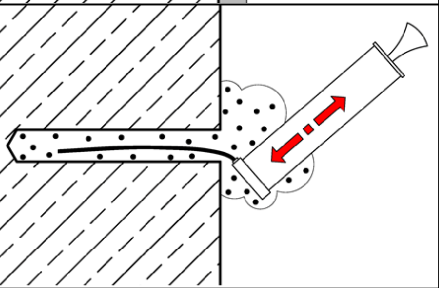
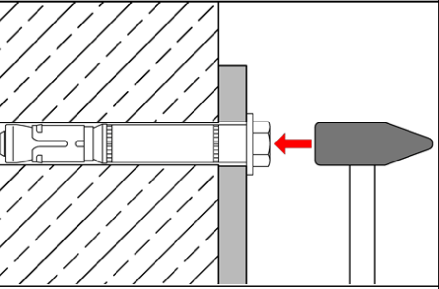
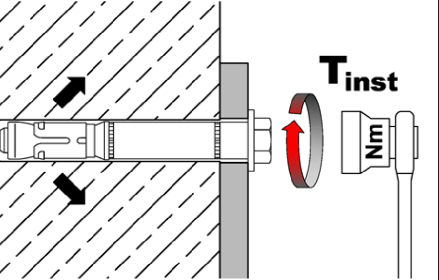
1		<p>Drill hole perpendicular to concrete surface. If using a vacuum drill bit, proceed with step 3.</p>
2		<p>Blow out dust. Alternatively vacuum clean down to the bottom of the hole.</p>
3		<p>Drive in fastener.</p>
4		<p>Apply installation torque <math>T_{inst}</math>.</p>

Highload Anchor SZ

Intended use  
Installation instructions

Annex B5

**Table C1:** Characteristic values for **tension load, cracked concrete,**  
static or quasi-static action, **steel zinc plated**

Fastener size			10/M6	12/M8	15/M10	18/M12	24/M16	24/ M16L	28/M20	32/M24
Installation factor	$\gamma_{inst}$	[-]	1,0							
<b>Steel failure</b>										
Characteristic resistance	$N_{Rk,s}$	[kN]	16	29	46	67	126	126	196	282
Partial factor	$\gamma_{Ms}$	[-]	1,5							
<b>Pull-out failure</b>										
Characteristic resistance in cracked concrete C20/25	$N_{Rk,p}$	[kN]	5	12	16	25	36	44	50	65
Increasing factor for $N_{Rk,p}$	$\psi_C$	[-]	$\left(\frac{f_{ck}}{20}\right)^{0,5}$							
<b>Concrete cone failure</b>										
Minimum effective anchorage depth	$h_{ef,min}$	[mm]	50	60	71	80	100	115	125	150
Maximum effective anchorage depth	$h_{ef,max}$	[mm]	76	100	110	130	114	150	185	210
Factor for cracked concrete	$k_1 = k_{cr,N}$	[-]	7,7							

**Highload Anchor SZ**

**Performance**

Characteristic values for **tension load, cracked concrete,** static or quasi-static action, **steel zinc plated**

**Annex C1**

**Table C2:** Characteristic values for **tension load, cracked concrete,**  
static or quasi-static action, **stainless steel A4**

Fastener size			12/M8	15/M10	18/M12	24/M16
Installation factor	$\gamma_{inst}$	[-]	1,0			
<b>Steel failure</b>						
<b>SZ-B</b>						
Characteristic resistance	$N_{Rk,s}$	[kN]	26	41	60	110
Partial factor	$\gamma_{Ms}$	[-]	1,5			
<b>SZ-S and SZ-SK</b>						
Characteristic resistance	$N_{Rk,s}$	[kN]	26	41	60	110
Partial factor	$\gamma_{Ms}$	[-]	1,87			
<b>Pull-out failure</b>						
Characteristic resistance in cracked concrete C20/25	$N_{Rk,p}$	[kN]	9	16	25	36
Increasing factor for $N_{Rk,p}$	$\psi_C$	[-]	$\left(\frac{f_{ck}}{20}\right)^{0,5}$			
<b>Concrete cone failure</b>						
Minimum effective anchorage depth	$h_{ef,min}$	[mm]	60	71	80	100
Maximum effective anchorage depth	$h_{ef,max}$	[mm]	100	110	130	150
Factor for cracked concrete	$k_1 = k_{cr,N}$	[-]	7,7			

**Highload Anchor SZ**

**Performance**  
Characteristic values for **tension load, cracked concrete,** static or quasi-static action,  
**stainless steel A4**

**Annex C2**

**Table C3: Characteristic values for tension load, uncracked concrete, static or quasi-static action, steel zinc plated**

Fastener size		10/M6	12/M8	15/M10	18/M12	24/M16	24/ M16L	28/M20	32/M24	
Installation factor	$\gamma_{inst}$ [-]	1,0								
<b>Steel failure</b>										
Characteristic resistance	$N_{Rk,s}$ [kN]	16	29	46	67	126	126	196	282	
Partial factor	$\gamma_{Ms}$ [-]	1,5								
<b>Pull-out failure</b>										
Characteristic resistance in uncracked concrete C20/25	$N_{Rk,p}$ [kN]	17	20	30	36	50	1)	70	1)	
Increasing factor for $N_{Rk,p}$	$\psi_C$ [-]	$\left(\frac{f_{ck}}{20}\right)^{0,5}$					-	$\left(\frac{f_{ck}}{20}\right)^{0,5}$		-
<b>Splitting failure</b> (The higher resistance of case 1 and case 2 may be applied)										
<b>Case 1</b>										
Characteristic resistance in uncracked concrete C20/25	$N^0_{Rk,sp}$ [kN]	12	16	25	30	40	70	50	70	
Edge distance	$c_{cr,sp}$ [mm]	1,5 $h_{ef}$								
Increasing factor for $N^0_{Rk,sp}$	$\psi_C$ [-]	$\left(\frac{f_{ck}}{20}\right)^{0,5}$								
<b>Case 2</b>										
Characteristic resistance in uncracked concrete	$N^0_{Rk,sp}$ [kN]	$\min(N_{Rk,p}; N^0_{Rk,c})$								
Edge distance	$c_{cr,sp}$ [mm]	2,5 $h_{ef}$					1,5 $h_{ef}$	2,5 $h_{ef}$	2 $h_{ef}$	
<b>Concrete cone failure</b>										
Minimum effective anchorage depth	$h_{ef,min}$ [mm]	50	60	71	80	100	115	125	150	
Maximum effective anchorage depth	$h_{ef,max}$ [mm]	76	100	110	130	114	150	185	210	
Edge distance	$c_{cr,N}$ [mm]	1,5 $h_{ef}$								
Factor for uncracked concrete	$k_1 = k_{ucr,N}$ [-]	11,0								

1)  $N_{Rk,p} = N^0_{Rk,c}$  calculated with  $h_{ef,min}$

**Highload Anchor SZ**

**Performance**  
Characteristic values for tension load, uncracked concrete, static or quasi-static action, steel zinc plated

**Annex C3**

**Table C4: Characteristic values for tension load, uncracked concrete, static or quasi-static action, stainless steel A4**

Fastener size			12/M8	15/M10	18/M12	24/M16
Installation factor	$\gamma_{inst}$	[-]	1,0			
<b>Steel failure</b>						
<b>SZ-B</b>						
Characteristic resistance	$N_{Rk,s}$	[kN]	26	41	60	110
Partial factor	$\gamma_{Ms}$	[-]	1,5			
<b>SZ-S and SZ-SK</b>						
Characteristic resistance	$N_{Rk,s}$	[kN]	26	41	60	110
Partial factor	$\gamma_{Ms}$	[-]	1,87			
<b>Pull-out failure</b>						
Characteristic resistance in uncracked concrete C20/25	$N_{Rk,p}$	[kN]	16	25	35	50
Increasing factor for $N_{Rk,p}$	$\psi_C$	[-]	$\left(\frac{f_{ck}}{20}\right)^{0,5}$			
<b>Splitting failure</b>						
Edge distance	$c_{cr,sp}$	[mm]	180	235	265	300
<b>Concrete cone failure</b>						
Minimum effective anchorage depth	$h_{ef,min}$	[mm]	60	71	80	100
Maximum effective anchorage depth	$h_{ef,max}$	[mm]	100	110	130	150
Edge distance	$c_{cr,N}$	[mm]	1,5 $h_{ef}$			
Factor for uncracked concrete	$k_1 = k_{ucr,N}$	[-]	11,0			

**Highload Anchor SZ**

**Performance**  
Characteristic values for tension loads, uncracked concrete, static or quasi-static action, stainless steel A4

**Annex C4**

**Table C5:** Characteristic values of **shear load**, static or quasi-static action, **steel zinc plated**

Fastener size			10/M6	12/M8	15/M10	18/M12	24/M16	24/ M16L	28/M20	32/M24
<b>Steel failure without lever arm</b>										
<b>SZ-B</b>										
Characteristic resistance	$V_{RK,s}^0$	[kN]	16	25	36	63	91	91	122	200
Ductility factor	$k_7$	[-]	1,0							
Partial factor	$\gamma_{Ms}$	[-]	1,25							
<b>SZ-S and SZ-SK</b>										
Characteristic resistance	$V_{RK,s}^0$	[kN]	18	30	48	73	126	126	150	200
Ductility factor	$k_7$	[-]	1,0							
Partial factor	$\gamma_{Ms}$	[-]	1,25							
<b>Steel failure with lever arm</b>										
<b>SZ-B, SZ-S und SZ-SK</b>										
Anchorage depth	$h_{ef,min} \geq$	[mm]	50	60	71	80	100	115	125	150
Characteristic bending resistance	$M_{RK,s}^0$	[Nm]	12	30	60	105	266	266	519	898
Partial factor	$\gamma_{Ms}$	[-]	1,25							
Anchorage depth	$h_{ef} \geq$	[mm]	64	73	90	106	138	138	158	188
Characteristic bending resistance	$M_{RK,s}^0$	[Nm]	40	58	119	234	529	529	847	1343
Partial factor	$\gamma_{Ms}$	[-]	1,25							
<b>Concrete pry-out failure</b>										
Pry-out factor	$k_8$	[-]	1,8 <sup>1)</sup>	2,0						
<b>Concrete edge failure</b>										
Effective length of fastener in shear loading	$l_f$	[mm]	$h_{ef}$							
Outside diameter of fastener	$d_{nom}$	[mm]	10	12	15	18	24	24	28	32

<sup>1)</sup>  $k_8 = 2,0$  for  $h_{ef} \geq 60$  mm

**Highload Anchor SZ**

**Performance**  
Characteristic values for **shear load**, static or quasi-static action, **steel zinc plated**

**Annex C5**

**Table C6:** Characteristic values for **shear load**, static or quasi-static action, **stainless steel A4**

Fastener size			12/M8	15/M10	18/M12	24/M16
<b>Steel failure without lever arm</b>						
Characteristic resistance	$V_{Rk,s}^0$ [kN]		24	37	62	92
<b>SZ-B</b>						
Ductility factor	$k_7$ [-]		1,0			
Partial factor	$\gamma_{Ms}$ [-]		1,25			
<b>SZ-S</b>						
Ductility factor	$k_7$ [-]		1,0			
Partial factor	$\gamma_{Ms}$ [-]		1,36			
<b>SZ-SK</b>						
Ductility factor	$k_7$ [-]		0,8			-
Partial factor	$\gamma_{Ms}$ [-]		1,36			-
<b>Steel failure with lever arm</b>						
Anchorage depth	$h_{ef,min} \geq$ [mm]		60	71	80	100
Characteristic bending resistance	$M_{Rk,s}^0$ [Nm]		26	52	92	232
<b>SZ-B</b>						
Partial factor	$\gamma_{Ms}$ [-]		1,25			
<b>SZ-S and SZ-SK</b>						
Partial factor	$\gamma_{Ms}$ [-]		1,56			
<b>SZ-B, SZ-S and SZ-SK</b>						
Anchorage depth	$h_{ef} \geq$ [mm]		73	90	106	138
Characteristic bending resistance	$M_{Rk,s}^0$ [Nm]		103	211	374	847
Partial factor	$\gamma_{Ms}$ [-]		1,25			
<b>Concrete pry-out failure</b>						
Pry-out factor	$k_8$ [-]		2,0			
<b>Concrete edge failure</b>						
Effective length of fastener in shear loading	$l_f$ [mm]		$h_{ef}$			
Outside diameter of fastener	$d_{nom}$ [mm]		12	15	18	24

**Highload Anchor SZ**

**Performance**  
Characteristic values for **shear load**, static or quasi-static action,  
**stainless steel A4**

**Annex C6**

**Table C7:** Characteristic values for seismic action, Category C1 and C2, steel zinc plated

Fastener size			12/M8	15/M10	18/M12	24/M16	24/M16L	28/M20	32/M24
Tension load									
Installation factor	$\gamma_{inst}$	[-]	1,0						
<b>Steel failure</b>									
Characteristic resistance category C1	$N_{Rk,s,eq,C1}$	[kN]	29	46	67	126	126	196	282
Characteristic resistance category C2	$N_{Rk,s,eq,C2}$	[kN]	29	46	67	126	126	196	282
Partial factor	$\gamma_{Ms}$	[-]	1,5						
<b>Pull-out failure</b>									
Characteristic resistance category C1	$N_{Rk,p,eq,C1}$	[kN]	12	16	25	36	44,4	50,3	63,3
Characteristic resistance category C2	$N_{Rk,p,eq,C2}$	[kN]	5,4	16,4	22,6	29,0	41,2	43,6	63,3
<b>Shear load</b>									
<b>Steel failure without lever arm</b>									
<b>SZ-B</b>									
Characteristic resistance category C1	$V_{Rk,s,eq,C1}$	[kN]	18,0	27,1	43,4	51,9	51,9	96,4	160,1
Characteristic resistance category C2	$V_{Rk,s,eq,C2}$	[kN]	12,7	20,5	31,5	50,1	50,1	67,1	108,1
<b>SZ-S</b>									
Characteristic resistance category C1	$V_{Rk,s,eq,C1}$	[kN]	18,0	27,1	43,4	51,9	51,9	96,4	160,1
Characteristic resistance category C2	$V_{Rk,s,eq,C2}$	[kN]	12,7	20,5	31,5	69,3	69,3	67,1	108,1
<b>SZ-SK</b>									
Characteristic resistance category C1	$V_{Rk,s,eq,C1}$	[kN]	25,2	36,5	50,4	-	-	-	-
Characteristic resistance category C2	$V_{Rk,s,eq,C2}$	[kN]	19,2	29,3	39,4	-	-	-	-
Factor for annular gap	$\alpha_{gap}$	[-]	0,5						
Partial factor	$\gamma_{Ms}$	[-]	1,25						

**Highload Anchor SZ**

**Performance**  
Characteristic values for seismic action, steel zinc plated

**Annex C7**

**Table C8: Characteristic values for seismic action, Category C1 and C2, stainless steel A4**

Fastener size			12/M8	15/M10	18/M12	24/M16
<b>Tension load</b>						
Installation factor	$\gamma_{inst}$	[-]	1,0			
<b>Steel failure</b>						
Characteristic resistance, category C1	$N_{Rk,s,eq,C1}$	[kN]	26	41	60	110
Characteristic resistance, category C2	$N_{Rk,s,eq,C2}$	[kN]	26	41	60	110
Partial factor SZ-B	$\gamma_{Ms}$	[-]	1,5			
Partial factor SZ-S and SZ-SK	$\gamma_{Ms}$	[-]	1,87			
<b>Pull-out failure</b>						
Characteristic resistance, category C1	$N_{Rk,p,eq,C1}$	[kN]	9	16	26	36
Characteristic resistance, category C2	$N_{Rk,p,eq,C2}$	[kN]	4,8	16,5	24,8	44,5
<b>Shear load</b>						
<b>Steel failure without lever arm</b>						
<b>SZ-B</b>						
Characteristic resistance, category C1	$V_{Rk,s,eq,C1}$	[kN]	9,6	13,3	25,4	75,4
Characteristic resistance, category C2	$V_{Rk,s,eq,C2}$	[kN]	9,7	14,0	18,0	32,2
Partial factor	$\gamma_{Ms}$	[-]	1,25			
<b>SZ-S</b>						
Characteristic resistance, category C1	$V_{Rk,s,eq,C1}$	[kN]	9,6	13,3	25,4	75,4
Characteristic resistance, category C2	$V_{Rk,s,eq,C2}$	[kN]	9,7	14,0	18,0	32,2
Partial factor	$\gamma_{Ms}$	[-]	1,36			
<b>SZ-SK</b>						
Characteristic resistance, category C1	$V_{Rk,s,eq,C1}$	[kN]	11,5	23,3	31,6	-
Characteristic resistance, category C2	$V_{Rk,s,eq,C2}$	[kN]	10,8	17,4	15,4	-
Partial factor	$\gamma_{Ms}$	[-]	1,36			-
Factor for annular gap	$\alpha_{gap}$	[-]	0,5			

**Highload Anchor SZ**

**Performance**  
Characteristic values for seismic action, stainless steel A4

**Annex C8**

**Table C9:** Characteristic values under **fire exposure** in cracked and uncracked concrete C20/25 to C50/60

Fastener size		10/M6	12/M8	15/M10	18/M12	24/M16	24/ M16L	28/M20	32/M24	
<b>Tension load</b>										
<b>Steel failure</b>										
<b>Steel zinc plated</b>										
Characteristic resistance	R30	$N_{Rk,s,fi}$	[kN]	1,0	1,9	4,3	6,3	11,6	18,3	26,3
	R60			0,8	1,5	3,2	4,6	8,6	13,5	19,5
	R90			0,6	1,0	2,1	3,0	5,0	7,7	12,6
	R120			0,4	0,8	1,5	2,0	3,1	4,9	9,2
<b>Stainless steel A4</b>										
Characteristic resistance	R30	$N_{Rk,s,fi}$	[kN]	-	6,1	10,2	15,7	29,2	-	-
	R60			-	4,4	7,3	11,1	20,6	-	-
	R90			-	2,6	4,3	6,4	12,0	-	-
	R120			-	1,8	2,8	4,1	7,7	-	-
<b>Shear load</b>										
<b>Steel failure without lever arm</b>										
<b>Steel zinc plated</b>										
Characteristic resistance	R30	$V_{Rk,s,fi}$	[kN]	1,0	1,9	4,3	6,3	11,6	18,3	26,3
	R60			0,8	1,5	3,2	4,6	8,6	13,5	19,5
	R90			0,6	1,0	2,1	3,0	5,0	7,7	12,6
	R120			0,4	0,8	1,5	2,0	3,1	4,9	9,2
<b>Stainless steel A4</b>										
Characteristic resistance	R30	$V_{Rk,s,fi}$	[kN]	-	14,3	22,7	32,8	61,0	-	-
	R60			-	11,1	17,6	25,5	47,5	-	-
	R90			-	7,9	12,6	18,3	34,0	-	-
	R120			-	6,3	10,0	14,6	27,2	-	-
<b>Steel failure with lever arm</b>										
<b>Steel zinc plated</b>										
Characteristic bending resistance	R30	$M^0_{Rk,s,fi}$	[Nm]	0,8	2,0	5,6	9,7	24,8	42,4	83,6
	R60			0,6	1,5	4,1	7,2	18,3	29,8	61,9
	R90			0,4	1,0	2,7	4,7	11,9	17,1	40,1
	R120			0,3	0,8	1,9	3,1	6,6	10,7	29,2
<b>Stainless steel A4</b>										
Characteristic bending resistance	R30	$M^0_{Rk,s,fi}$	[Nm]	-	6,2	13,2	24,4	61,8	-	-
	R60			-	4,5	9,4	17,2	43,6	-	-
	R90			-	2,7	5,6	10,0	25,3	-	-
	R120			-	1,8	3,6	6,4	16,2	-	-

**Highload Anchor SZ**

**Performance**  
Characteristic values under **fire exposure**

**Annex C9**

**Table C10: Displacements under tension and shear load, steel zinc plated**

Fastener size			10/ M6	12/ M8	15/ M10	18/ M12	24/ M16	24 /M16L	28/ M20	32/ M24
<b>Tension load</b>										
Tension load in cracked concrete	N	[kN]	2,4	5,7	7,6	12,3	17,1	21,1	24	26,2
Displacement	$\delta_{N0}$	[mm]	0,5	0,5	0,5	0,7	0,8	0,7	0,9	1,4
	$\delta_{N\infty}$	[mm]	2,0	2,0	1,3	1,3	1,3	1,3	1,4	1,9
Tension load in uncracked concrete	N	[kN]	8,5	9,5	14,3	17,2	24	29,6	34	43
Displacement	$\delta_{N0}$	[mm]	0,8	1,0		1,1		1,3	0,3	0,7
	$\delta_{N\infty}$	[mm]	3,4			1,7		2,3	1,4	0,7
<b>Seismic action C2</b>										
Displacement for DLS	$\delta_{N,eq}(DLS)$	[mm]	-	3,3	3,0	5,0	3,0	3,0	4,0	5,3
Displacement for ULS	$\delta_{N,eq}(ULS)$	[mm]	-	12,2	11,3	16,0	9,2	9,2	13,8	12,4
<b>Shear load</b>										
<b>SZ-B</b>										
Shear load in cracked and uncracked concrete	V	[kN]	9,1	14	20,7	35,1	52,1	52,1	77	86,6
Displacement	$\delta_{V0}$	[mm]	2,5	2,1	2,7	3,0	5,1	5,1	4,3	10,5
	$\delta_{V\infty}$	[mm]	3,8	3,1	4,1	4,5	7,6	7,6	6,5	15,8
<b>Seismic action C2</b>										
Displacement for DLS	$\delta_{V,eq}(DLS)$	[mm]	-	2,3	3,1	3,0	2,6	2,6	1,6	6,1
Displacement for ULS	$\delta_{V,eq}(ULS)$	[mm]	-	4,8	6,4	6,1	6,6	6,6	4,8	9,5
<b>SZ-S</b>										
Shear load in cracked and uncracked concrete	V	[kN]	10,1	17,1	27,5	41,5	72	72	77	86,6
Displacement	$\delta_{V0}$	[mm]	2,9	2,5	3,6	3,5	7,0	7,0	4,3	10,5
	$\delta_{V\infty}$	[mm]	4,4	3,8	5,4	5,3	10,5	10,5	6,5	15,8
<b>Seismic action C2</b>										
Displacement for DLS	$\delta_{V,eq}(DLS)$	[mm]	-	2,3	3,1	3,0	3,3	3,3	1,6	6,1
Displacement for ULS	$\delta_{V,eq}(ULS)$	[mm]	-	4,8	6,4	6,1	8,2	8,2	4,8	9,5
<b>SZ-SK</b>										
Shear load in cracked and uncracked concrete	V	[kN]	10,1	17,1	27,5	41,5	-	-	-	-
Displacement	$\delta_{V0}$	[mm]	2,9	2,5	3,6	3,5	-	-	-	-
	$\delta_{V\infty}$	[mm]	4,4	3,8	5,4	5,3	-	-	-	-
<b>Seismic action C2</b>										
Displacement for DLS	$\delta_{V,eq}(DLS)$	[mm]	-	3,1	3,9	3,9	-	-	-	-
Displacement for ULS	$\delta_{V,eq}(ULS)$	[mm]	-	10,2	11,8	13,0	-	-	-	-

**Highload Anchor SZ**

**Performance**  
Displacements under tension and shear load, steel zinc plated

**Annex C10**

**Table C11: Displacements under tension and shear load, stainless steel A4**

Fastener size		12/M8	15/M10	18/M12	24/M16
<b>Tension load</b>					
Tension load in cracked concrete	N [kN]	4,3	7,6	12,1	17,0
Displacement	$\delta_{N0}$ [mm]	0,5	0,5	1,3	0,5
	$\delta_{N\infty}$ [mm]	1,2	1,6	1,8	1,6
Tension load in uncracked concrete	N [kN]	7,6	11,9	16,7	24,1
Displacement	$\delta_{N0}$ [mm]	0,2	0,3	1,2	1,5
	$\delta_{N\infty}$ [mm]	1,1	1,1	1,1	1,1
<b>Seismic action C2</b>					
Displacement for DLS	$\delta_{N,eq (DLS)}$ [mm]	4,7	4,5	4,3	4,9
Displacement for ULS	$\delta_{N,eq (ULS)}$ [mm]	13,3	12,7	9,7	10,1
<b>Shear load</b>					
Shear load in cracked concrete	V [kN]	13,9	21,1	34,7	50,8
Displacement	$\delta_{V0}$ [mm]	3,4	4,9	4,8	6,7
	$\delta_{V\infty}$ [mm]	5,1	7,4	7,1	10,1
<b>Seismic action C2</b>					
<b>SZ-B and SZ-S</b>					
Displacement for DLS	$\delta_{V,eq (DLS)}$ [mm]	2,8	3,1	2,6	3,3
Displacement for ULS	$\delta_{V,eq (ULS)}$ [mm]	5,6	5,8	5,0	6,9
<b>SZ-SK</b>					
Displacement for DLS	$\delta_{V,eq (DLS)}$ [mm]	2,5	2,8	2,9	-
Displacement for ULS	$\delta_{V,eq (ULS)}$ [mm]	5,8	5,9	6,9	-

**Highload Anchor SZ**

**Performance**  
Displacements under tension and shear load, stainless steel A4

**Annex C11**