

Declaration of Performance

2323-CPR-0041

1. Unique identification code of the product-type: Mungo ceiling anchor MAN for multiple use for non-structural applications in concrete

2. Manufacturer: Mungo Befestigungstechnik AG, Bornfeldstrasse 2, CH-4600 Olten - Switzerland

3. System/s of AVCP: System 2+

4. Intended use or use/es:

Product	Intended use
Multiple use for non-structural applications in non-cracked and cracked concrete	The anchor is to be used for static or quasi-static loading in reinforced or unreinforced normal weight concrete of strength classes C20/25 to C50/60 according to EN 206-1

5. European Assessment Document: ETAG 001 – Part 6 (Used as EAD)

European Technical Assessment: ETA-06/0168 of 2016/08/11

Technical Assessment Body: DIBt – Deutsches Institut für Bautechnik

Notified body/ies: 2323 (IEA) acc. No. 305/2011 (Construction Product Regulation EU)

6. Declared performance:

Mechanical resistance and stability (BWR 1)

Essential characteristic	Performance
Characteristic resistance for all load directions	See appendix, especially Annex C1
Installation parameters	See appendix, especially Annex B2

Safety in case of fire (BWR 2)

Essential characteristic	Performance
Resistance to fire	See appendix, especially Annex C1
Reaction to fire	Satisfy requirements for Class A1

The performance of the product identified above is in conformity with the set of declared performance/s. This declaration of performance is issued, in accordance with Regulation (EU) No 305/2011, under the sole responsibility of the manufacturer identified above.

Signed for and on behalf of the manufacturer by:



Dipl.-Ing. Robert Klemencic
Head of Engineering
Olten, 2020-11-11



This DoP has been prepared in different languages. In case there is a dispute on the interpretation the English version shall always prevail. The Appendix includes voluntary and complementary information in English language exceeding the (language as neutrally specified) legal requirements.

**Only for multiple use for non-structural applications
according to ETAG 001, Part 6, Annex 1**

Head marking: Identifying mark of the producer
and anchor type

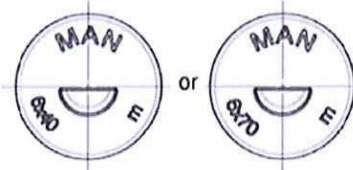
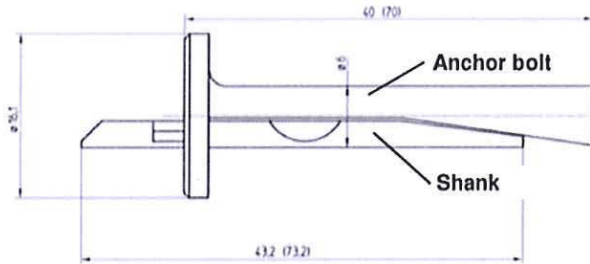

Installed condition for mungo MAN ceiling anchor

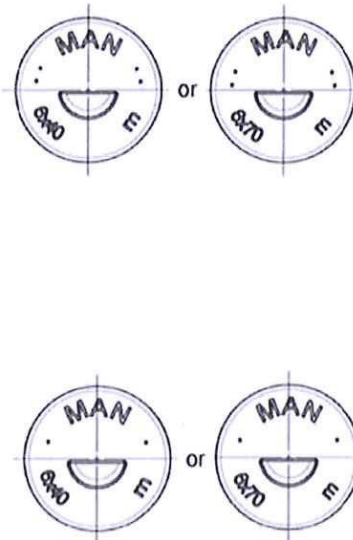
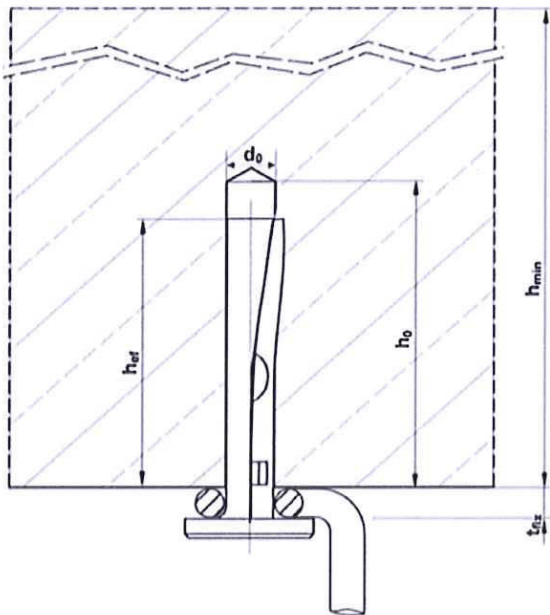

Table A1: Anchor dimension, marking and material

mungo MAN ceiling anchor		6 x 40	6 x 70
Marking / embossing		MAN 6 x 40	MAN 6 x 70
Anchor length	[mm]	40	70
Material	Anchor bolt	Strength class 4.8 according to EN ISO 898-1:2013 galvanized steel, Zinc plating $\geq 5 \mu\text{m}$ according to EN ISO 4042:1999	
	Shank	Strength class 8.8 according to EN ISO 898-1:2013; galvanized steel, Zinc plating $\geq 5 \mu\text{m}$ according to EN ISO 4042:1999	

mungo ceiling anchor MAN

Product description
Installed condition, anchor types, dimensions and materials

Annex A1

Specifications of intended use

Anchorage subject to:

- Static and quasi-static loads
- Multiple fixing of non-structural applications
- Fire exposure

Base materials:

- Reinforced or unreinforced normal weight concrete according to EN 206-1:2000
- Strength classes C20/25 to C50/60 according to EN 206-1:2000
- Non-cracked and cracked concrete

Use conditions:

- Structures subject to dry internal conditions

Design:

- The anchorages are to be designed under the responsibility of an engineer experienced in anchorages and concrete work.
- Verifiable calculation notes and drawings shall be prepared taking account of the loads to be anchored, the nature and strength of the base materials and the dimensions of the anchorage members as well as of the relevant tolerances. The position of the anchor shall be indicated on the design drawings (e. g. position of the anchor relative to reinforcement or to supports, etc.).
- Anchorages under static or quasi-static actions are designed in accordance with ETAG 001, Annex C, design method C, Edition August 2010.
- Anchorages under fire exposure are designed in accordance with ETAG 001, Annex C, design Method C, Edition August 2010 and EOTA Technical Report TR 020, Edition May 2004. It must be ensured that local spalling of the concrete cover does not occur.
- Fasteners are only to be used for multiple use for non-structural application, according to ETAG 001 Part 6, Edition January 2011.

Installation:

- Dry or wet concrete
- Anchor installation has to be carried out by appropriately qualified personnel according to Annex B2 under the supervision of the person responsible for technical matters of the site.
- Hole drilling by hammer drilling
- Anchor expansion by impact on the shank. The anchor is properly set, if no further driving by impact is possible and the excess of the shank is at maximum 2,5 mm.
- The anchor may only be set once.

mungo ceiling anchor MAN

**Intended use
Specifications**

Annex B1

Table B1: Installation parameters

mungo MAN ceiling anchor			MAN 6 x 40	MAN 6 x 70
Effective anchorage depth	$h_{ef} \geq$	[mm]	32	
Thickness of fixture	t_{fix}	[mm]	0 - 5	0 - 35
Nominal drill hole diameter	d_o	[mm]	6	
Max. drill bit diameter	d_{cut}	[mm]	6,4	
Drill hole depth	$h_o \geq$	[mm]	40	
Minimum thickness of concrete member	h_{min}	[mm]	80	
Minimum spacing	s_{min}	[mm]	200	
Minimum edge distance	c_{min}	[mm]	150	

Installation instructions:



Make the drill hole

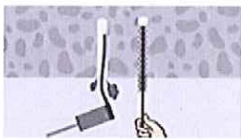

Clean the drill hole from drill dust

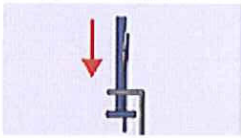

Place the fixture on the ceiling anchor

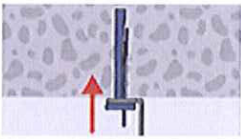

Place the ceiling anchor with the fixture concisely into the hole

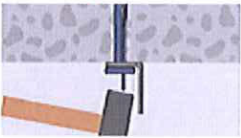

Drive in the nail with a hammer

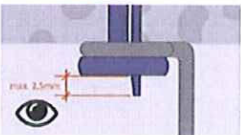

Installed ceiling anchor; control of maximum overlap of shank:
 $\leq 2,5 \text{ mm}$

mungo ceiling anchor MAN

Intended use
Installation parameters, edge distance and spacing
Installation instructions

Annex B2

Table C1: Characteristic values of resistance in concrete in all load directions (Design according to ETAG 001, Annex C, design method C)

mungo MAN ceiling anchor			MAN 6 x 40	MAN 6 x 70
All load directions				
Characteristic resistance in concrete C20/25 to C50/60	F_{Rk}	[kN]	3,0	
Installation safety factor	γ_2	[-]	1,0	
Minimum spacing	s_{min}	[mm]	200	
Minimum edge distance	c_{min}	[mm]	150	
Shear load with lever arm				
Characteristic bending moment	$M_{Rk,s}^0$ ¹⁾	[Nm]	5,4	
Installation safety factor	γ_2	[-]	1,0	

¹⁾ Characteristic bending moment $M_{Rk,s}^0$ for Equation (5.5) in ETAG 001, Annex C

Only for multiple use for non-structural applications, the definition of multiple use according to the member states is given in the Informative Annex 1 of ETAG 001, Part 6

Table C2: Characteristic values under fire exposure in cracked and non-cracked concrete C20/25 to C50/60 in all load directions without lever arm (Design according to EOTA TR 020)

Fire resistance class	mungo MAN ceiling anchor			MAN 6 x 40	MAN 6 x 70
R 30	Characteristic resistance	$F_{Rk,fi}^0$ ¹⁾	[kN]	0,6	
R 60				0,5	
R 90				0,4	
R 120				0,3	
R 30 - R 120	Minimum spacing	$s_{min,fi}$	[mm]	200	
	Minimum edge distance ²⁾	$c_{min,fi}$	[mm]	150	

¹⁾ In absence of other national regulations, the partial safety factor for resistance under fire exposure $\gamma_{m,fi} = 1,0$ is recommended.

²⁾ In case of fire attack from more than one side of the concrete member, the edge distance shall be ≥ 300 mm.

mungo ceiling anchor MAN

Performances

Characteristic resistances in concrete
Design method C according to ETAG 001, Annex C

Annex C1