



U BOLTS

Hot Dip Galvanised / Zinc Plated

1/4"BSW ROUND U BOLT KIT MILD STEEL (incl. 2 Nuts)

Part	Finish	A	Nominal Bore	W	L	T	Pack	Pack Wgt (Kg)
KURMSZW0250050	Z/P	1/4"	1/2"	7/8"	2 3/8"	1 1/2"	100	2.92
KURMSZW0250075	Z/P	1/4"	3/4"	1 1/16"	2 11/16"	1 1/2"	100	3.22
KURMSZW0250100	Z/P	1/4"	1"	1 3/8"	2 7/8"	1 1/2"	100	3.46
KURMSZW0250125	Z/P	1/4"	1 1/4"	1 11/16"	3 3/16"	1 1/2"	100	3.87
KURMSZW0250150	Z/P	1/4"	1 1/2"	1 15/16"	3 7/16"	1 1/2"	100	4.14
KURMSZW0250200	Z/P	1/4"	2"	2 3/8"	3 7/8"	1 1/2"	100	4.61

BSW ROUND U BOLT KIT MILD STEEL (incl. 2 Nuts)

Part	Finish	A	Nominal Bore	W	L	T	Pack	Pack Wgt (Kg)
KURMSGW0370050	HDG	3/8"	1/2"	7/8"	2 5/8"	1 3/4"	50	4.61
KURMSGW0370075	HDG	3/8"	3/4"	1 1/16"	3 1/16"	2"	50	5.19
KURMSGW0370100	HDG	3/8"	1"	1 3/8"	3 3/8"	2"	50	5.58
KURMSZW0370100	Z/P	3/8"	1"	1 3/8"	3 3/8"	2"	50	5.58
KURMSGW0370125	HDG	3/8"	1 1/4"	1 11/16"	3 11/16"	2"	50	6.02
KURMSGW0370150	HDG	3/8"	1 1/2"	1 15/16"	3 15/16"	2"	50	6.34
KURMSGW0370200	HDG	3/8"	2"	2 3/8"	4 3/8"	2"	50	7.02
KURMSZW0370200	Z/P	3/8"	2"	2 3/8"	4 3/8"	2"	50	7.02
KURMSGW0500250	HDG	1/2"	2 1/2"	3"	5"	2"	25	6.80
KURMSGW0500300	HDG	1/2"	3"	3 1/2"	5 1/2"	2"	25	7.63
KURMSZW0500300	Z/P	1/2"	3"	3 1/2"	5 1/2"	2"	25	7.63
KURMSGW0500350	HDG	1/2"	3 1/2"	4"	6"	2"	25	8.23
KURMSGW0500400	HDG	1/2"	4"	4 1/2"	6 1/2"	2"	10	3.55
KURMSGW0500500	HDG	1/2"	5"	5 5/16"	7 5/16"	2"	10	4.08
KURMSGW0500600	HDG	1/2"	6"	6 5/8"	8 5/8"	2"	10	4.61
KURMSGW0620800	HDG	5/8"	8"	8 5/8"	11 5/8"	2"	10	9.78
KURMSGW0751000	HDG	3/4"	10"	10 3/4"	14 3/4"	2"	5	9.15
KURMSGW0751200	HDG	3/4"	12"	12 3/4"	16 3/4"	2"	1	2.06

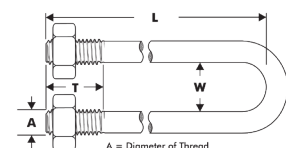
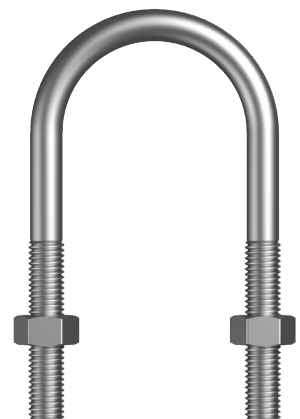
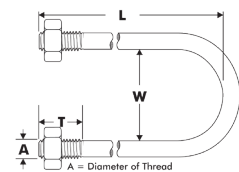
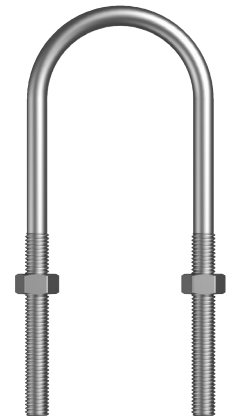

Disclaimer: while every reasonable effort has been made to ensure that this document is correct at the time of printing, Hobson Engineering®, its agencies and employees disclaim all liability in respect to anything or the consequences of anything done or omitted regarding the whole or any part of this document.



TECHNICAL

U BOLTS

Hot Dip Galvanised / Zinc Plated

METRIC ROUND U BOLT KIT MILD STEEL (incl. 2 Nuts)

Part	Finish	A	Nominal Bore	W	L	T	Pack	Pack Wgt (Kg)
KURMSGCM100021	HDG	M10	15	21	65	40	50	4.83
KURMSGCM100027	HDG	M10	20	27	77	50	50	5.56
KURMSGCM100034	HDG	M10	25	34	85	50	50	6.04
KURMSGCM100043	HDG	M10	32	43	93	50	50	6.55
KURMSGCM100048	HDG	M10	40	48	100	50	50	7.09
KURMSGCM100051	HDG	M10	40	51	103	50	50	7.16
KURMSGCM100060	HDG	M10	50	60	110	50	50	7.60
KURMSGCM120076	HDG	M12	65	76	127	50	25	6.38
KURMSGCM120089	HDG	M12	80	89	140	50	25	6.93
KURMSGCM120102	HDG	M12	90	102	152	50	25	7.47
KURMSGCM120114	HDG	M12	100	114	165	50	10	3.22
KURMSGCM120140	HDG	M12	125	140	190	50	10	3.68
KURMSGCM120165	HDG	M12	150	165	215	50	10	4.13
KURMSGCM120168	HDG	M12	150	168	220	50	10	4.20
KURMSGCM160219	HDG	M16	200	219	295	75	10	10.24
KURMSGCM200273	HDG	M20	250	273	370	100	5	10.06
KURMSGCM200324	HDG	M20	300	324	420	100	1	2.26
KURMSGCM200356	HDG	M20	350	356	455	100	1	2.47
KURMSGCM200406	HDG	M20	400	406	505	100	1	2.72
KURMSGCM240457	HDG	M24	450	457	555	100	1	4.35
KURMSGCM240508	HDG	M24	500	508	605	100	1	4.80
KURMSGCM240610	HDG	M24	600	610	710	100	1	5.54

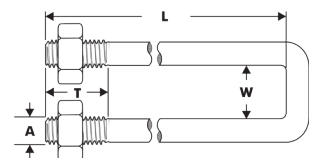
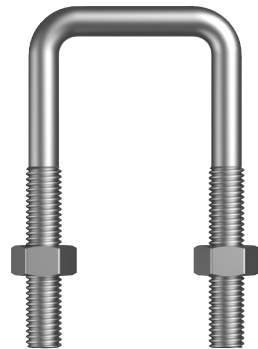
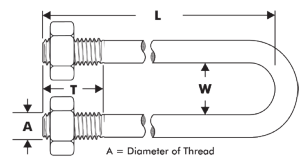
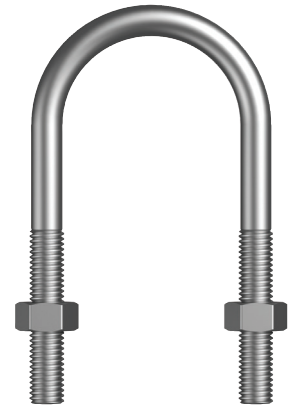

METRIC SQUARE U BOLT KIT MILD STEEL (incl. 2 Nuts)

Part	Finish	A	W	L	T	Pack	Pack Wgt (Kg)
KUSMSGCM10042086	HDG	M10	42	86	55	50	6.58
KUSMSZCM10042086	Z/P	M10	42	86	55	50	6.58
KUSMSZCM10042127	Z/P	M10	42	127	55	50	8.57

Disclaimer: while every reasonable effort has been made to ensure that this document is correct at the time of printing, Hobson Engineering®, its agencies and employees disclaim all liability in respect to anything or the consequences of anything done or omitted regarding the whole or any part of this document.

Bolt Tension | Anti-Vibration | Product Reliability | Traceability

hobson.com.au **QUALITY FASTENERS SINCE 1935**





U BOLTS

Hot Dip Galvanised

METRIC SQUARE U BOLT KIT MILD STEEL (incl. 2 Nuts & 2 Spring Washers)

Part	Finish	A	W	L	T	Pack	Pack Wgt (Kg)
KUSMSGSM10024060	HDG	M10	24	60	40	50	3.93
KUSMSGSM12042115	HDG	M12	42	115	50	25	5.64
KUSMSGSM12044110	HDG	M12	44	110	50	25	5.50
KUSMSGSM12052080	HDG	M12	52	80	50	25	4.59
KUSMSGSM12052110	HDG	M12	52	110	50	25	5.64
KUSMSGSM12052145	HDG	M12	52	145	50	25	6.87
KUSMSGSM12052165	HDG	M12	52	165	50	25	7.58
KUSMSGSM12067090	HDG	M12	67	90	50	25	5.20
KUSMSGSM12077080	HDG	M12	77	80	50	25	5.03
KUSMSGSM12077110	HDG	M12	77	110	50	25	6.08
KUSMSGSM12127160	HDG	M12	127	160	50	10	3.49

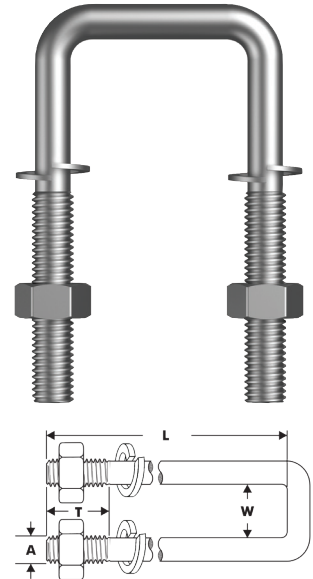

Disclaimer: while every reasonable effort has been made to ensure that this document is correct at the time of printing, Hobson Engineering®, its agencies and employees disclaim all liability in respect to anything or the consequences of anything done or omitted regarding the whole or any part of this document.